

# Building Construction

# 8

Section I - Firefighting Fundamentals



**Loads & Forces**

**Building Codes**

**Building Materials**

**Building Components**

**Classifications of Buildings**

**Building Collapse**



*Intentionally Left Blank*



# Chapter 8 Table of Contents

Objectives .....	8-1
Introduction.....	8-2
Loads.....	8-3
Types of Loads.....	8-3
Imposition of Loads.....	8-4
Forces.....	8-4
Deformation.....	8-4
Building Codes.....	8-5
Building Materials .....	8-6
Stone .....	8-6
Masonry .....	8-6
Concrete.....	8-7
Steel .....	8-8
Wood.....	8-8
Composites .....	8-9
Fasteners & Connectors.....	8-10
Building Components .....	8-11
Foundations.....	8-11
Walls .....	8-12
Insulation .....	8-16
Roof Construction.....	8-17
Ceilings.....	8-28
Doors & Windows .....	8-28
Building Construction Classifications.....	8-29



Type I – Fire Resistive ..... 8-29

Type II – Non-Combustible/Limited Combustible ..... 8-29

Type III – Ordinary Construction ..... 8-30

Type IV – Heavy Timber ..... 8-30

Type V – Wood Frame Construction ..... 8-31

Building Collapse..... 8-32

    Signs of Potential Collapse ..... 8-32

    Buildings Under Construction ..... 8-32

    Time ..... 8-32

Summary ..... 8-34

Media & Links Index ..... 8-35

References..... 8-36

Revisions/Updates..... 8-37



# Objectives

- Understand the significance of loads and other forces on a structure
- Define the types of loads and forces, and how they affect structural integrity
- Understand the purpose of building codes
- Understand the types of the materials used in construction
- Define key building components and their role in the structure
- Define key terms associated with building construction
- Describe the types of foundations
- Describe the types of walls and their components
- Describe the types of roofs and their components
- Understand the hazards of truss construction
- Define the five classifications of building construction
- Describe the signs and indicators of a potential building collapse



# Introduction



Figure 8-1 Building Collapse - FDNY

The most important reason for understanding building construction is safety. Firefighters should be able to identify the types of building construction, associated terminology and components, to know when it is no longer safe to remain in or on a building. Firefighters must be familiar with the basics of building construction and how a fire in a particular building can affect its structural integrity. Knowing common building construction terminology will allow firefighters to understand and interpret building construction experts who may be called to a structure fire. Firefighters must also have an understanding of the major components of a building and be aware of their associated

strengths and weaknesses, including roof types. When attacking a fire, this knowledge will help to avoid serious injury or death due to the hazards associated with a particular type of construction.

Buildings may collapse for a variety of reasons including stress, poor construction, deterioration, or fire. Firefighters should be aware of the potential and imminent indicators of building collapse, [Figure 8-1](#). They should be able to inspect a building and identify those indicators that may lead to building collapse, both under normal conditions and during fire suppression operations. These indicators, in some cases, may help avoid or alleviate risk. Firefighters must know what to do under these circumstances and when it is no longer safe to remain in, on, or near the building.

Another important aspect of building construction that firefighters must be concerned with is building classifications and the basic differences between each type. Since buildings vary in type, design, and construction methods, each will have its own unique fire problems and hazards. Therefore, firefighters who are familiar with the type of building classification and associated collapse hazards ahead of time will do a better job of containing the structure fire and will be safer.



# Loads

A comprehensive understanding of building construction requires basic knowledge of the concept of loads and how they are applied. Loads are forces that are placed upon structural components. Forces such as the weight of the building caused by gravity, wind, rain and earthquakes all can affect structural stability.

Loads fall into two broad categories, Figure 8-2.

- **Dead Loads** – A dead load is the weight of the building and any part of the structure that is permanently attached to it. Dead loads may also be considered static, as they change very little.
- **Live Loads** – A live load is the weight of occupants, furniture, movable equipment, stored materials and forces of movement.



Figure 8-2 Dead Vs. Live Loads

## Types of Loads

Loads can be further broken down into the following categories.

- **Concentrated Load** – A load which is applied to a small or specific area. An HVAC system on a roof is considered a concentrated load.
- **Distributed Load** – A load which is applied equally over a wide or large area. A roof would be considered a distributed load as it has multiple anchor points to exterior walls that help disburse its weight.
- **Impact Load** – An impact load is a load in motion caused by vibration, impact or acceleration. An item falling from the ceiling and striking the floor would be considered an impact load.
- **Design Load** – A load that has been calculated or anticipated by the architect or building engineer.
- **Undesigned Load** – A load that was not anticipated or planned for when the building was constructed. An example of an undesigned load would be an office building converted into a warehouse. These structures were not originally designed to hold the new dead or live loads now occupying it.
- **Fire Load** – The heat generated by all the structural components of a building and its contents when it is burning. This heat is measured in British Thermal Units or BTU's.

## Imposition of Loads

As a result of these loads, weight is transferred to other structural members as the structure reacts to the load placed upon it. This transfer of weight is known as the imposition of loads. There are three basic applications of how loads are transferred from one structural member to another, Figure 8-3.

- Axial Loading – A load that passes through the center of mass of the supporting element and is perpendicular to the cross section.
- Eccentric Loading – A load that is perpendicular to the cross section of the supporting element and does not pass through the center of mass.

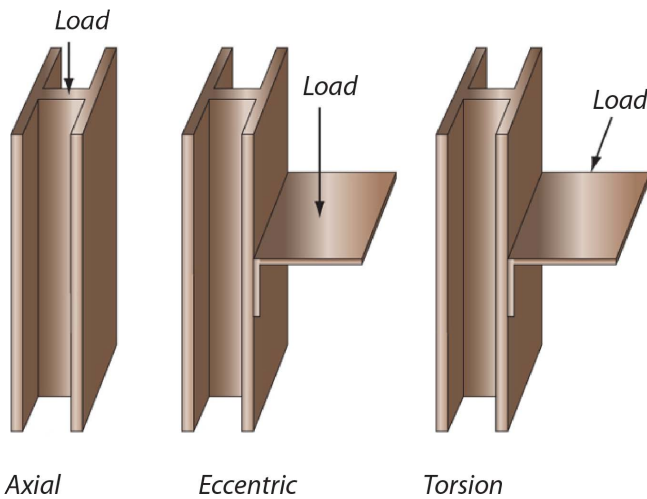

- Torsion Loading – A load that is parallel to the cross section of the supporting member and does not pass through the long axis. Twisting is a result from this type of load.

## Forces

When a load or force is applied to a material, stress is placed on that material. Stress can be categorized in three ways, Figure 8-4.

- Compression – Causes the shortening of a material.
- Tension – Causes the elongation of a material.
- Shear – Causes a material to tear or slide apart.

Figure 8-3 Imposition of Loads

## Deformation

When enough stress is placed on an object, deformation will occur. Deformation is the change in size and shape of a material after a material has reacted to the stress placed upon it. A material's strength or ability to compensate for this stress is an extremely important factor considered by architects and building engineers. Material strength is measured through testing and its reactions, which can be characterized in the following manner.

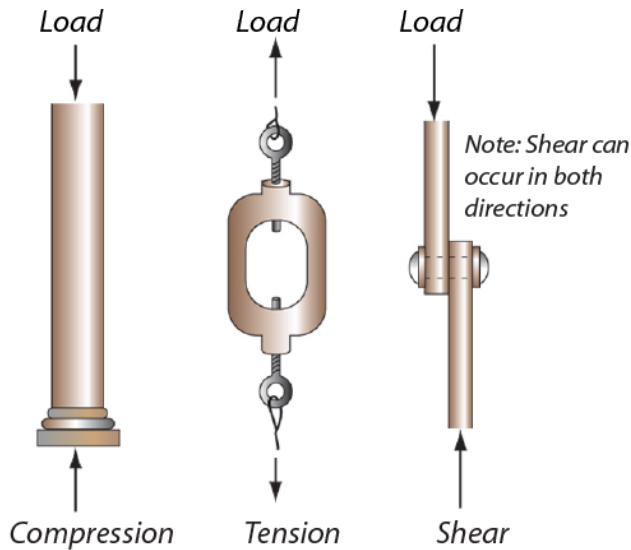

- Elastic – When a material returns to its original shape.
- Yielding – When a material does not return to its original shape.
- Ductile – When a material displays large amounts of deformation before failure.
- Brittle – When a material shows little or no deformation before failure.

Graphic Courtesy of Del Mar/Cengage Learning

Figure 8-4 Forces





# Building Codes

The purpose of building codes are to protect public health, safety, and general welfare as they relate to the construction and occupancy of buildings and structures. The building code becomes law of a particular jurisdiction when formally enacted by the appropriate authority. Building codes are legal documents and are enforced through the power of the states, which is then delegated to local municipalities. Building codes cover all aspects of new construction as well as renovation and remodeling and are designed to prevent building failure.

The Uniform Building Code is one of several building codes in existence. The UBC is primarily used in the western United States, however, California has created a stricter building code to meet its unique needs such as earthquake safety. The 2007 California Building Code is currently the adopted code under which the City of San Diego operates.

# Building Materials



Figure 8-5 Solid Stone Construction

It is important to understand the types of materials and their properties used in building construction in order to assess the strengths and weaknesses of a structure. Although new construction techniques are constantly being implemented, the behaviors and properties of the raw materials used in building construction generally do not change.

## Stone

Stone is one of the oldest building materials known to man. It has been used in construction for thousands of years. Because of the weight, shape, and texture of stone, it was often laid or set without a bonding agent, known as dry-stacking, Figure 8-5. Granite, limestone, sandstone and marble are all examples of stone. Stone structures are extremely hard and durable and typically have thick walls.

Solid stone structures are not very common in San Diego and are primarily found in older cities and along the east coast. Stone is primarily used for decorative purposes such as wall coverings and facades in California. This type of stone usage is often found in newer construction and should be treated with respect due to its weight.

## Masonry

Masonry is the building of structures from individual units laid in and bound together by mortar. Masonry is generally a highly durable form of construction. However, the materials used, the quality of the mortar, workmanship, and the pattern in which the units are assembled can significantly affect the durability of the overall masonry construction.

Masonry is commonly used for the walls of buildings, retaining walls and monuments. Brick and concrete block are the most common types of masonry in use and may be either weight bearing or a decorative veneer.

Traditional brick is comprised mainly of clay that is fired in a kiln. In many older parts of San Diego, such as downtown, buildings were constructed using a 12" x 12" hollow clay brick. The hollow clay brick has since been replaced by concrete block, also known as "Cinder Block," for modern day construction. Cinder block is made from Portland cement, water and aggregates and is commonly produced in an 8" x 8" x 16" size, Figure 8-6. Mortar, is used to bind the brick or blocks together and is comprised of lime, sand and water. Mortar is generally the weakest link in masonry construction and the cause for failures.

Masonry performs excellent when placed under compression but does not



Figure 8-6 Traditional Brick, Hollow Clay Brick, Cinder Block



stand up well to horizontal or lateral loads found during an earthquake or high wind. Masonry also expands and fails under extended fire conditions.

A unique characteristic of masonry materials is efflorescence, Figure 8-7. Efflorescence is a natural event that happens when moisture seeps from the material and evaporates. When the moisture evaporates, it leaves behind the salts and impurities that were found in the water to form a white powder. Efflorescence is merely cosmetic in nature and does not affect the structural integrity of the material.



Figure 8-7 Efflorescence

Often masonry construction is coated with a masonry-based mortar, called parging, to improve a building's appearance, Figure 8-8. Unlike stucco, parging is trowelled directly onto the surface of the masonry brick or block and creates a smooth surface for painting and other cosmetic improvements. The hazard of parging to firefighters is that it can hide cracks or other imperfections that can compromise the buildings structural integrity. There are numerous buildings in the Gaslamp and Downtown areas of San Diego where parging has been used.



Figure 8-8 Parging

## Concrete

Concrete is a synthetic construction material made by mixing cement, fine aggregates (sand), coarse aggregates (gravel or crushed stone), and water in the proper proportions. The activating ingredient for concrete is water. Once water is introduced to the concrete mix, a chemical reaction begins and hardens the fluid mix. Although concrete may be hard enough to walk on within an hour, it will not reach its full strength until it is fully cured 28 days later.

Concrete is the most economical, versatile and widely used construction material in use today. It is found in all types of structures such as bridges, high rise buildings, tunnels, and vaults. One of its greatest attributes is its ability to withstand extremely high compression stress and weight. It is very weather resistant and can be easily molded and formed into any shape or size, Figure 8-9.



Figure 8-9 Concrete Construction

The drawback to concrete is its inability to perform well while placed under tension. Concrete has very little tensile strength and needs to be in a state of constant compression to be strong. To compensate for this, steel bars are placed within the concrete during the pour to reinforce itself when cured. These steel bars are known as re-bar, Figure 8-10. Concrete can be further strengthened by applying tension to the rebar with hydraulic rams; anchors are then attached to the ends of the re-bar so that when the tension on the rams is released, the concrete is compressed by the tensioned re-bar within. This process is known as Pre-Tensioning and Post-Tensioning of concrete.



Figure 8-10 Steel Rebar

- Pre-Tensioning - The re-bar has been placed under tension prior to the concrete being poured, then the tension is slowly released once the concrete has cured to achieve compression.
- Post-Tensioning - The re-bar or steel cabling is placed within a protective sleeve and concrete is poured and cured around it. The re-bar is then ten-

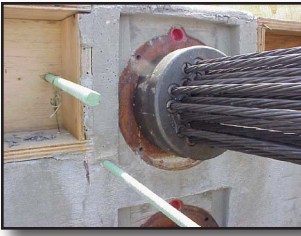

Figure 8-11 Post Tensioned Concrete Anchor

sioned, secured with an anchor and released to achieve compression, Figure 8-11.

Pre-tensioned and post-tensioned concrete can be hazardous to firefighters because of the amount of potential energy they harness. If the concrete fails, the compressive forces placed upon them may release violently expelling debris and causing unpredictable movement.

Although concrete generally performs better than most materials under fire conditions, after prolonged exposure to heat spalling will occur. Spalling occurs when the moisture trapped within the concrete heats up and expands to form a gas; it explosively releases, discharging pieces of concrete with it. Spalling will cause cracks and holes in the concrete and will eventually lead to the weakening or failure of the material.



Figure 8-12 Steel Construction

## Steel

Steel is used widely in the construction of roads, railways, other infrastructure, appliances, and buildings. Most large modern structures, such as stadiums, skyscrapers, bridges, and airports are supported by a steel skeleton, Figure 8-12. Even those with a concrete structure will employ steel for reinforcement.

Steel is an alloy which is made from iron ore, carbon, and other additives. By changing the amount of these additives, engineers can modify steel properties to meet their particular needs. In the modern construction industry, steel typically comes in the form of I-beams, H-Columns, and re-bar.

Steel performs well under tension and under compression. However, the biggest drawback to steel is that it expands and weakens very quickly when heat is applied to it, thereby losing its properties of tensile and compressive strength. As a general rule, a steel beam will expand 1% of its length incrementally for every 1000 degrees of heat it is exposed to. For example, a 50' steel beam exposed to 1000 degrees of heat could be expected to expand 6 inches.

Engineers have found that combining concrete and steel together make an incredibly strong partnership. When steel rebar is placed inside a concrete column, it forms a material that holds up well under compression force (concrete) and tensile force (steel). This material is known as steel-reinforced concrete.



Figure 8-13 Wood Construction

## Wood

Wood is just about the only product used in the building industry that is natural, Figure 8-13. Wood has many unique characteristics and advantages. It is easy to cut and manipulate. It contains a cellular structure that makes it possible to drive nails, screws, and other fasteners into. Wood is light-weight, absorbs sound, does not transmit heat well, and is readily available.

The drawback to wood is that it burns quite easily. Because wood is a natural material, it will also rot and decay over time.

Most wood used in the construction industry is Douglas fir, pine, or redwood



Figure 8-14 Plywood





and comes in standard sizes and lengths. Plywood is a relatively new technology which has revolutionized the construction industry. Plywood consists of thin plies of wood that are glued together to form wood panels, most commonly found in 4' x 8' sheets, Figure 8-14. Plywood comes in varying thickness and is used for many applications such as roof decking and sub floors.

A newer type of paneling that is cheaper and an alternative to plywood is oriented strand board or OSB, Figure 8-15. OSB is made by reusing wood chips, flakes, sawdust and other debris left behind after milling. This material is all added to a binder such as glue and is pressed together in layers to form flat sheets of wood similar to plywood.

OSB and Plywood are dangerous to firefighters because of their high glue, paraffin and wood flake content. This type of wood will quickly fail under heat and fire conditions.

## Composites

New technologies have led to new composite building materials. These new materials have increased the hazards of fire fighting in various ways; lowering flash points, creating toxic gases and failing quickly when exposed to heat. Below are just a few of the many different types of composite materials in use by the construction industry today.

- Vinyl
- Plastic
- Fiberglass, Figure 8-16
- Glue
- Aluminum
- Styrofoam, Figure 8-17
- Fiber Board

It is important for firefighters to continuously stay abreast of new products being used in construction and to be aware of the hazards they pose.



Figure 8-15 Oriented Strand Board (OSB)



Figure 8-16 Fiberglass Panels

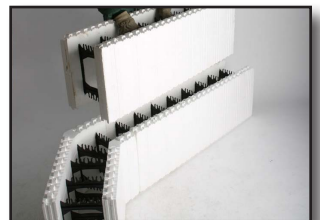

Figure 8-17 Styrofoam Block Forms for Concrete

## Fasteners & Connectors



Nail



Wood Screw

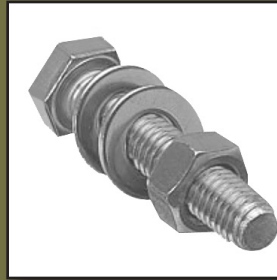

Bolt, Washer, Nut



Concrete Anchors



Gusset Plate

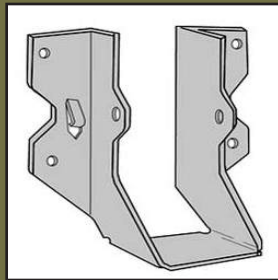

Joist Hanger



Plywood Clip



Post Connector

## Fasteners & Connectors

Structural components must be connected in order to transfer loads effectively. Often the connection or fastener is the weakest point and causes structures to fail. Fasteners and connectors are typically made out of a light-weight metal that lacks the ability to absorb or withstand heat. Fasteners and connectors come in many different shapes, styles, and forms and are continuously evolving. Some of the more common fasteners and connectors are listed below.

- Nails
- Screws
- Bolts, washers, nuts
- Anchors
- Gusset plates
- Joist hangers
- Plywood clips
- Post connectors



# Building Components

Firefighters must be able to look at a structure and quickly make a size-up or assessment of what they see. In order for firefighters to determine which tools and equipment we will grab, which tactics they will choose, and what safety measure they will employ, they need to be able to quickly identify the different features and components of the structure.

## Foundations

A foundation is the base of the structure and is responsible for all weight distribution from the roof to the ground. It must be strong enough to support all weight from above, yet resist lateral forces such as wind and shaking from earthquakes. There are two common types of foundations found in San Diego.

### Raised Foundation

In a raised foundation, the weight of a home is distributed between an exterior stem wall and a series of posts installed under the home mounted to piers, wedge-shaped concrete blocks, which distribute the weight across the ground, *Figure 8-16*. Typically, the stem wall will run the perimeter of the structure while the post and piers are located at key points in the middle of the home to ensure that the floors, as well as the rest of the house, do not sag.

Raised foundation construction is a technique used to build the foundation of a house quickly and cheaply. This type of foundation is typically found in older homes that were built prior to 1950.

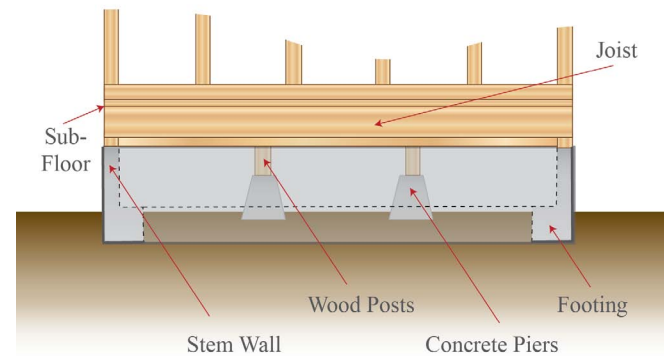

Figure 8-18 Raised Foundation

### Concrete Slab Foundation

Concrete foundations use formed concrete, embedded with rebar for added strength, to create slabs which support the structure, *Figure 8-19*. Concrete slab foundations are found in new residential construction and all commercial applications.

### Basements

Although not common in San Diego, there are a few structures in the city which have basements. It is important to look for signs of a basement during your size-up. Items such as windows at the street level and descending staircases may indicate there is a basement.

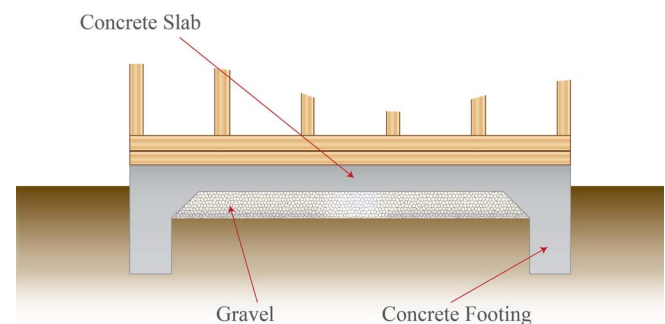

Figure 8-19 Concrete Slab Foundation

## Walls

Walls are the vertical support members for the structure. Walls are generally categorized into two distinct categories, load bearing and non-load bearing.

- A load bearing wall is one that supports the weight of the roof or any floors located above the wall to the foundation.
- A non-load bearing wall is one that is used to separate spaces or create an enclosure and does not support any weight from overhead. Most interior walls are non-load bearing.

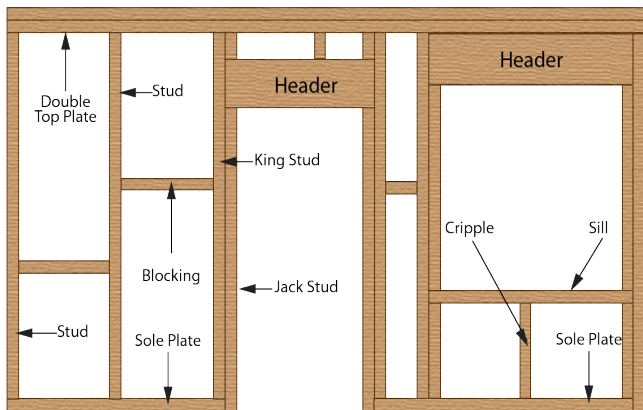

Figure 8-20 Wood Wall Framing

### Wall Components

Walls can be constructed from masonry, concrete, wood, and lightweight steel. Wood walls and lightweight steel walls are most commonly found in residential and interior commercial structures. Concrete and masonry are typically used as exterior walls in commercial buildings in San Diego.

#### *Wood and Lightweight Steel Walls*

Wood and lightweight steel walls are very similar in their construction. They also use similar terminology to describe their components, Figure 8-20.

- Columns – Any structural component that transmits a compressive force or axial load. They may stand alone or be integrated into a wall to support beams or any other vertical load.
- Fire Blocking – Horizontal wood members that are placed between studs to stop the spread of fire vertically through the wall.
- Studs – Studs are vertical members of a wall and are typically spaced 12, 16, or 24 inches apart.
- Sole Plate – A sole plate is the bottom horizontal member of a wall (pressure treated lumber).
- Top Plate – A top plate is the top horizontal member of a wall
- Header – A header is the horizontal member over a window or door
- Sill – A sill is the horizontal member below a window
- Cripples – Cripples are the vertical studs that are found below a sill or above a header.

#### *Concrete Walls*

Concrete walls are found in most newly constructed low-rise commercial buildings. A construction method called “tilt-up” construction is used for buildings because of its speed and cost savings compared to that of masonry. In tilt-up construction, concrete walls are poured into forms laid horizontally



on site. The concrete is reinforced with rebar and left to cure in place. Once cured, the concrete wall is raised vertically with a crane and anchored in place.

Concrete walls constructed in this method rely on the roof for stability. If you are fighting a fire in a building with tilt-up construction and the roof collapses or fails, the walls will become very unstable and have a high likelihood of falling over.

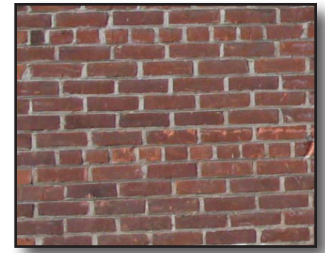

Figure 8-21 Unreinforced Masonry Wall

### Masonry Walls

Masonry walls are also used in low-rise commercial buildings. It is important to try and determine if the walls are reinforced or un-reinforced masonry. Un-reinforced masonry is no longer allowed per the building code, but is still found in many structures downtown.

Un-reinforced masonry is typically recognizable by the small traditional red bricks and mortar joints, Figure 8-21. Many of these un-reinforced masonry structures have been retrofitted with horizontal steel rods that stabilize the wall against shear or lateral forces. Buildings that have these tie rods can be identified on the exterior by looking for star plates, which is where the tie rods connect to the exterior walls.

Walls constructed of masonry such as cinder block, allow for the insertion of steel rebar and concrete into the core of the block. This type of construction is considered reinforced masonry and is found to be very strong and fire resistive.

### Wall Construction Method

Firefighters will encounter wood-framed walls that have been constructed in two distinct methods. Their difference may seem slight, but the differences in their behavior during fire conditions is quite drastic.

#### Balloon Wall Construction - Pre WW II Era

In older style balloon-frame construction, exterior wall studs are continuous from the foundation to the roof, Figure 8-22. The lack of fire blocking in this style of framing poses a very significant danger to firefighters and is no longer permitted per the California Building Code. Fire that has entered into the walls of a ballooned framed structure can easily spread vertically and uninhibited to upper floors and the attic due to the lack of fire blocking and top plates. Interior fire fighting conditions can decrease dramatically and without warning while

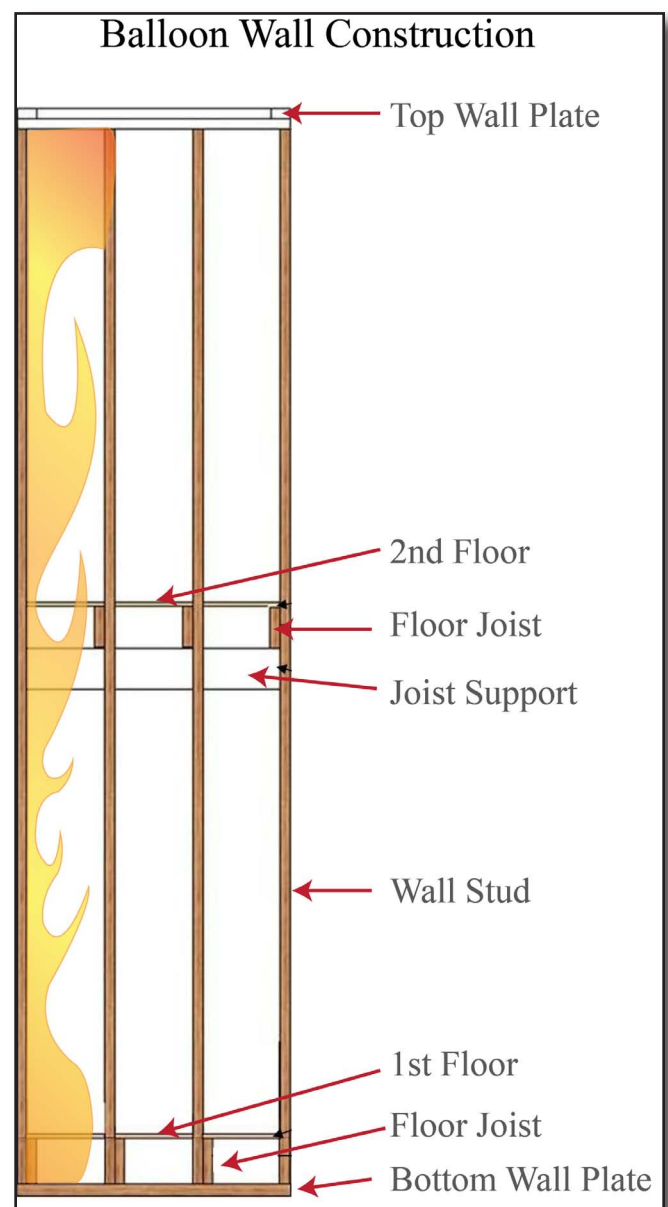

Figure 8-22 Balloon Wall Construction

fighting fires in balloon framed buildings. Although balloon-frame construction is no longer permitted, there are many older commercial and multi-story residential structures still in existence in San Diego that were built using this technique.

*Platform Wall Construction - Post WWII Era*

In platform-frame construction, floor joists are sheathed with sub-flooring, such as plywood or oriented strand board. The wall framing is then assembled flat on the floor and is tilted into place. The sole plate of the wall is fastened through the sub floor into the framing beneath. Today this is the most popular type of construction used in home building, Figure 8-23.

Platform construction provides a structural framework that is fire blocked by virtue of the style of construction. The wall sole plates and top plates isolate the horizontal floor cavity from the vertical wall cavity, as required by building codes, and prevent the vertical spread of fire.

**Wall Types**

Walls can be classified into a number of different categories.

*Interior Walls*

Interior walls are walls where both sides are contained within the building. They can be either load bearing or non-load bearing and do not contain insulation. Interior walls are used to separate rooms of the structure and are covered with any combination of lath & plaster, drywall, wood paneling, or other synthetic material.

*Exterior Walls*

Exterior walls have one side exposed to the outside and are typically load bearing and contain insulation. They are used to form the perimeter of the structure and support the roof. Exterior walls can be made of any combination of materials including concrete, masonry, vinyl, stucco, wood, or steel.

*Party Walls*

A party wall supports and separates two adjacent structures and may be either load bearing or non-load bearing. Party walls are typically found in apartment or condominium complexes wherein the wall is common to both structures.

*Fire Walls*

A fire wall is a common wall that divides a building into separate areas and is designed to withstand

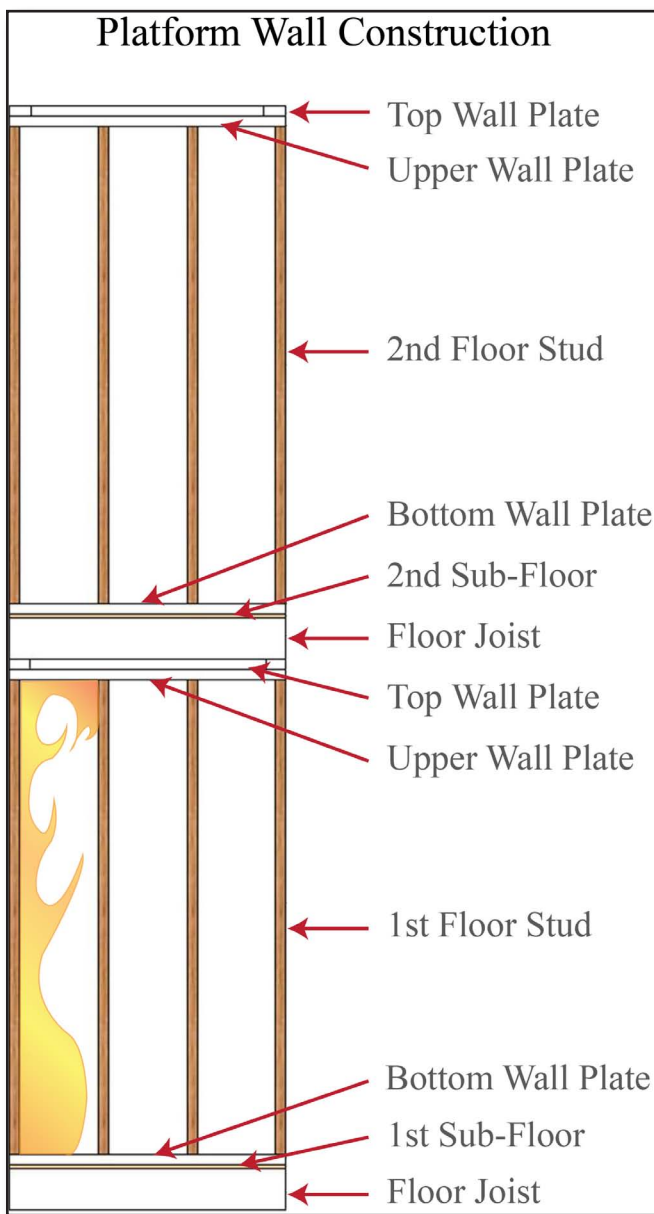

Figure 8-23 Platform Wall Construction



fire exposure. It is also designed to act as a barrier to fire spread with little or no assistance from fire fighting forces. Fire walls are rated by the number of hours of protection they provide. For example, a one-hour fire wall is required in all residential structures between the garage and the house. All openings in fire walls must be protected by automatically closing fire doors.

On larger structures, fire walls can be identified by their parapets which extend above the roof line. Fire walls can be load bearing or non-load bearing walls.

### *Veneer Walls*

A veneer wall is a decorative exterior facing wall that commonly has masonry or stone applied to it. These walls are used to improve the appearance of a building or structure and are usually non-load bearing in nature. Caution should be used around veneer walls because they can often be very heavy and are typically only tied to the main structure using metal ties every 16 inches. Fire and heat can cause these ties to fail causing the veneer wall to collapse regardless of whether the hidden structural wall is sound.

### *Parapet Walls*

A parapet wall extends vertically beyond the roof line and is free standing. Parapet walls are designed purely for aesthetics and are non-load bearing, Figure 8-24. These walls hide unsightly building components on the roof such as air conditioners, exhaust systems, and electrical panels. Parapet walls can be very dangerous as they are not typically supported by any other members.

When laddering a building with a parapet, beware of the drop off on the other side. Often a second ladder is necessary to climb down the backside of tall parapet walls to access the roof. A good indicator of how tall a parapet wall is above the roof line is to look for scupper holes (water drain outlets). Scupper holes are typically right above the roof line level.

### *Curtain Walls*

A curtain wall is an exterior, non-load bearing wall more than one story in height. Curtain walls are supported by the frame of the structure. Curtain walls are commonly found on the exterior of many high rise and commercial structures in the form of large glass panels.

## Wall Coverings

Walls can be faced or covered with a variety of materials. Commercial structures may have exterior walls constructed of masonry, stone, concrete, steel, vinyl, and even glass. Exterior walls for residential structures in Southern California are predominantly constructed of chicken wire mesh coated with

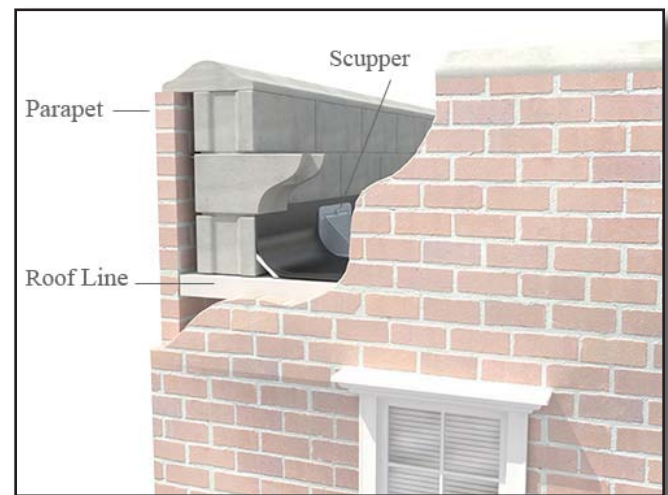

Figure 8-24 Parapet Wall



stucco. These walls can be quite strong and difficult to breach for firefighters as the chicken wire mesh makes the stucco difficult to break apart.



Figure 8-25 Lathe & Plaster construction

Interior walls are typically covered with the same material for both commercial and residential structures. Drywall, also known as “sheet rock,” is a fire retardant material that is commonly applied to the wall studs. Drywall is inexpensive and relatively easy for firefighters to breach during fire fighting operations and overhaul.

In older style residential structures built prior to WWII, lathe and plaster was commonly used. Lathe and plaster consists of thin strips of wood being applied to the studs of the wall horizontally, then a layer of plaster placed over top, Figure 8-25. Often chicken wire is used in lathe and plaster to give the wall added strength. The wall coating is very hard and durable but difficult for firefighters to breach.

## Insulation

The purpose of insulation is to minimize the temperature fluctuations that occur naturally inside of your home compared to that of the outside air temperature by using the least amount of energy as possible. Per the CBC, all exterior walls and ceilings must be insulated. Insulation is primarily constructed out of spun fiberglass and comes in pre-cut rolls or batts. Other types of insulation include “blown in” fiberglass insulation and spray foam, Figure 8-26.

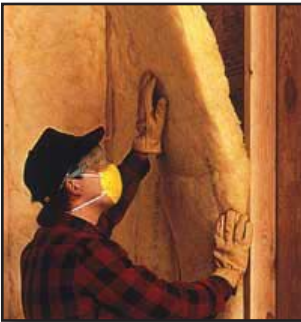

Figure 8-26 Fiberglass Batt, Blown-In and Spray Foam Insulation

Although fiberglass insulation is required to be non-flammable, it does have a paper vapor barrier attached to one side of the insulation that will burn. Fiberglass insulation poses a challenge for firefighters as it will smolder and retain high amounts of heat. Thorough overhaul and removal of any questionable insulation should be performed while fighting a structure fire to prevent a rekindle. Fiberglass insulation also poses a significant respiratory and health hazard when disturbed. Full PPE and respiratory protection should be utilized whenever handling or removing insulation.





## Roof Construction

Roofs protect occupants and the rest of the structure from the elements. Roofs have evolved quite drastically over time as builders search for cheaper and more effective construction methods. Firefighters must understand the types of roofs and their construction as they can pose great hazards to our operations. Roofs are typically the first structural members to fail in a fire resulting in collapse and trapping or killing firefighters.

### Anatomy of a Roof

Firefighters need to be able to identify and recognize the components of a standard roof in order to communicate effectively during fire ground operations. Included in this chapter are many terms used to describe building construction materials and techniques. There will be many cases where there is one or more terms that may be commonly used to describe the same thing. The terms used in this manual are not all-inclusive and some degree of flexibility for different terminology must be afforded.

Below are the basic components of a standard roof, Figure 8-27.

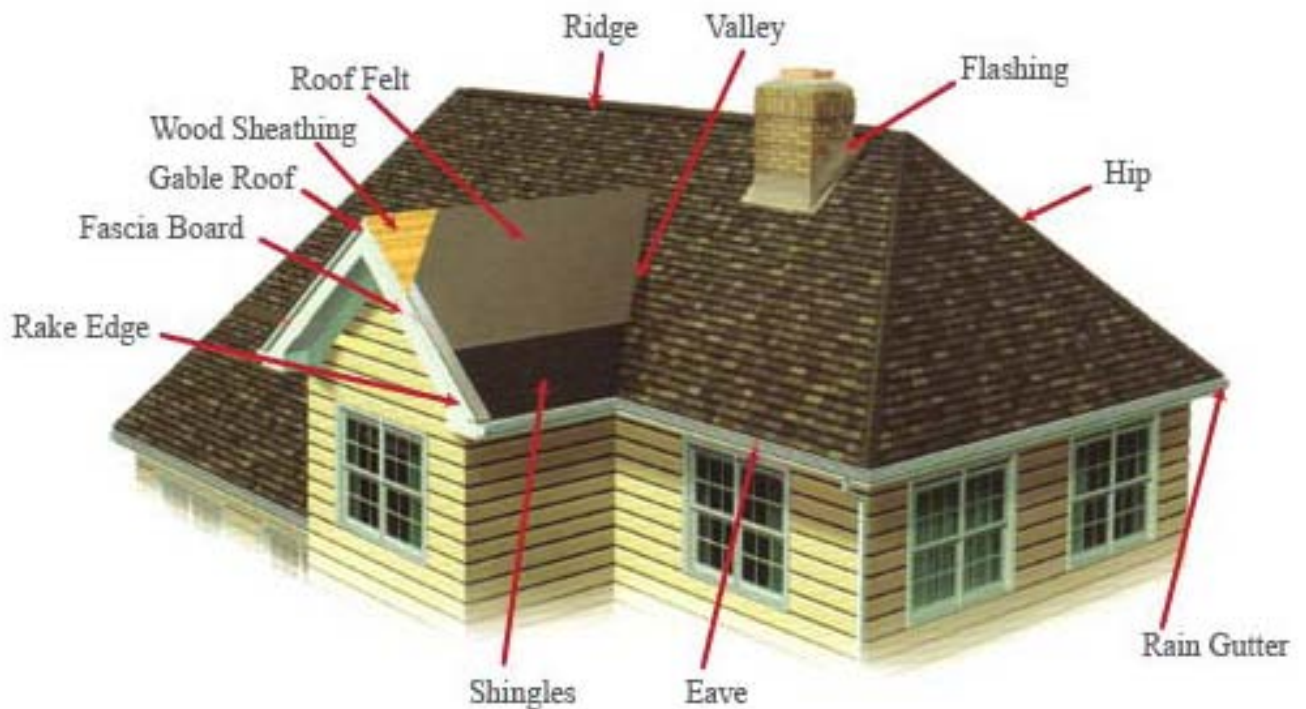

Figure 8-27 Anatomy of a Roof



Figure 8-28 Wood Shake Shingles

## Roofing Materials

During fire fighting and roof ventilation procedures, there are a number of roof coverings that will be encountered. It is important for firefighters to familiarize themselves with the different materials used, as well as the strengths and hazards of each. In this way, the proper method for safe and expedient vertical ventilation can be used.

### *Wood shake shingles*

Wood shingles, or shakes, are split pieces of red cedar wood used for roofing or siding, Figure 8-28. They are usually attached to 1 x 6 inch skip sheeting. Newer wooden shakes are now treated with fire retardant.

- **Strengths:**
  - Walking on rafters offers most support.
- **Hazards:**
  - Wood shakes are combustible.
  - Skip sheeting offers little support when weighted.

### *Asphalt composition shingles*

This shingle consists of a fiberglass mat that is impregnated with asphalt and faced with a granular stone aggregate, Figure 8-29. Plywood is placed over rafters and tar paper or felt is placed on top of the plywood. Finally, the shingle is stapled or nailed over the felt. These shingles may lay flat or have a dimensional look similar to wood shake shingles. Asphalt composition shingles are very common in pre-1980 residential roofs in San Diego that have a pitch.



Figure 8-29 Asphalt Composition Shingle

- **Strengths:**
  - Walking on the rafters, valley rafters or ridgepole offers the best support.
- **Hazards:**
  - This material will melt and burn.

### *Asphalt Composite Roll*

Asphalt composite roll roofing material is similar to the asphalt composition shingle in its construction, only it comes in rolls of 3 feet wide by 30 feet long instead of flat mats, Figure 8-30. Due to its low cost and speed to install, the composite roll is very popular in commercial and residential structures that have a flat roof or very low pitch. It is also common for new layers of composite roll to be placed over top of older layers when new roofing material is applied.

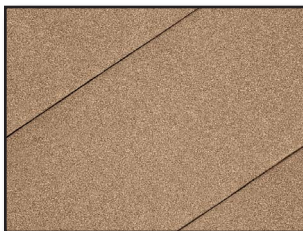

Figure 8-30 Asphalt Composite Roll

- **Strengths:**
  - Walking on the beams, purlins, and other main structural members will offer the best support.
- **Hazards:**
  - This material will melt and burn.



- Several layers of composite rolled material may be encountered during vertical ventilation operations making cutting more difficult.

### *Hot mop and rock*

Hot mop and rock requires hot tar to be spread onto plywood or OSB sheeting, followed by asphalt-impregnated felt to be rolled over top. With the tar still hot, small rock or aggregate is then spread to further protect the roof, Figure 8-30. This material is used predominately on flat roofs.

- **Strengths:**
  - Walking on joists and over exterior walls.
- **Hazards:**
  - This material will melt and burn.
  - Since this is typically used on flat roofs, firefighters will encounter lightweight construction methods on more recent homes.
  - Under heavy fire conditions, this type of roof can fail quickly.



Figure 8-31 Hot Mop & Rock Roof

### *Tile*

Tiles can be constructed from a variety of materials.

- Slate
- Clay
- Concrete

Clay and concrete tile can be either spanish style, Figure 8-32, or flat. Tile roofs are found on pitched roofs in both new and old home construction in San Diego. Typically, a tile roof is sheeted with plywood or OSB with wood batts nailed to the sheeting. The tiles are then secured to the wooden batts. During vertical ventilation operations, tiles are easily removed by hand to reveal the plywood sheeting for cutting.

- **Strengths**
  - The overlap area offers the most support.
  - The tiles are non-combustible.
- **Hazards**
  - Stability and signs of roof integrity are masked.
  - Tiles can be extremely slippery when wet.
  - When ventilating, tiles must be removed and can slide off the roof and cause injury.
  - Ridge caps must be removed before a roof ladder can safely be hooked over the ridge board.
  - Tiles are heavy, if trusses are exposed to fire, the roof will collapse rapidly.

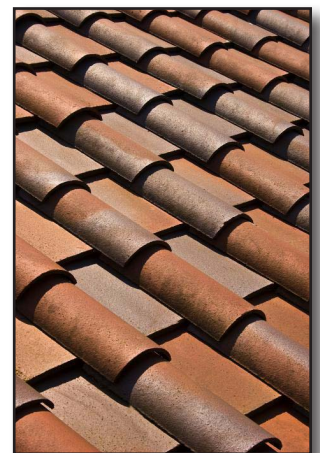

Figure 8-32 Spanish Tile Roof



Figure 8-33 Lightweight Concrete Roof

### *Lightweight Concrete*

Lightweight concrete can also be utilized as a roofing material, Figure 8-33. Corrugated metal decking is attached to a wood or steel framing structure. Then an air-entrained mixture of sand, cement and a small aggregate is pumped on the top of the metal decking to a thickness of about 3 to 4 inches. Because concrete can absorb moisture, it is necessary to seal it. Often, a rubberized roof membrane is applied over the top of the concrete as its final layer.

- **Strengths**
  - Creates a strong hard surface.
  - Structurally sound and fire resistant.
- **Hazards**
  - Difficult to vertically ventilate.



Figure 8-34 Metal Roof

### *Metal*

Metal roofing is a Class I (non-combustible) lightweight roofing material that comes in panels. The roofing panels can appear smooth with ridges, Figure 8-34, be coated in stone and have the look of tile, Figure 8-35, or can resemble the traditional wood shake roof. This type of roofing material prevents embers from igniting roofs during wind-driven fires. As building codes in the wildland/urban interface become stricter, this type of roofing material has become more prevalent in California.

Metal roofing can be installed directly over an existing wood shake roof. This makes it easy and less expensive to install. The panels are placed on a 2' x 2' batten and 1' x 4' counter-batten grid system, Figure 8-36. To strengthen the roof, the panels are staggered like brick work and nailed horizontally. One indication of this type of roofing is the oversized metal trim, of 4' to 6', found on the fascia boards and the end caps. Another indication is the steel roofing panels will not break when struck by a sledge or axe. Sounding and/or walking on the roof should be done at the bottom of the panels where the battens are located. Avoid areas that feel hot and sticky underfoot.



Figure 8-35 Stone Coated Metal Roof

- **Strengths**
  - Strongest part of roof is at the bottom of the panels where the battens are located.
  - Panels are non-combustible.
- **Hazards**
  - Metal roofs allow for rapid and undetected fire spread under the new roof. Because steel roofs are often applied over existing combustible roofs, a roughly 4" space is created between the old and new roof allowing for the fire to spread rapidly.
  - Not commonly encountered by firefighter's, leading to unfamiliarity with this type of roofing material and how to remove it.



Figure 8-36 Batten Grid System for Metal Roof





## Beams

A beam is a structural element that transfers loads perpendicular to its length and is a key element in roof construction. A beam is supported by a wall or column and is used to create a horizontal or covered space. The forces applied to a beam cause the top side of the beam to be in compression and the bottom side to be placed under tension. The distance from the top of the beam to the bottom of the beam indicates how much weight the beam can carry. Beams are also utilized in floor construction as well.

There are several types of beams that firefighters should be familiar with:

- Girder – A beam that supports other beams.
- Simple Beam – A beam that is supported at two points near its end.
- Continuous Beam – A beam that is supported in three or more places.
- Purlin – A series of wood beams placed perpendicular to other beams or trusses to support large area roofs and decking.
- Joist – Horizontal supporting members that run from wall to wall, wall to beam, or beam to beam to support a ceiling, roof or floor.
- Ridge Pole - A horizontal beam at the ridge of a roof to which the rafters are attached.
- Rafter - is one of a series of sloped structural members (beams), that extend from the ridge or hip to the downslope perimeter or eave, designed to support the roof deck and its associated loads.
- Lintel – A beam that spans an opening over a doorway or window. Also referred to as a “header.”

## Conventional Roof Construction

Conventional roof construction is an aging style of construction that is less commonly used today than 50 years ago. Conventional roof construction uses large wooden members such as 2 x 10's and 2 x 12's and solid wood or laminated beams to build the framework of the roof, Figure 8-37. Conventional roofs are quite strong and will generally hold up well under fire conditions due to the large size of lumber used. Conventional roof construction has been slowly replaced with light weight roof construction because it is faster, cheaper and requires less skill to construct.

Conventional roof construction can be found in many existing residential and commercial applications in San Diego.

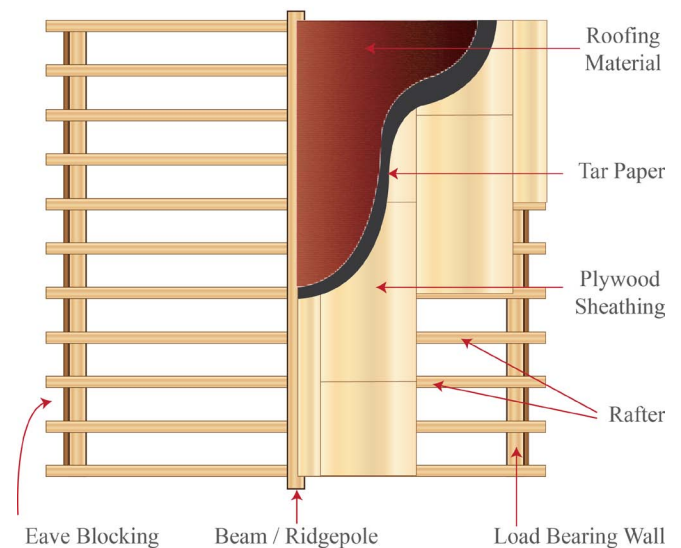

Figure 8-37 Conventional Roof Construction

### *Conventional Flat or Pitched Roof*

Conventional roofs consist of wood joists or rafters in various sizes that sit upon the outside walls or are suspended by metal hangers to the walls. These rafters and joists are then covered by 1 x 6 wood sheathing, or plywood, and composition roofing material.

- **Strengths**

- Typically hold up to fire and heat fairly well, but is highly dependant on the size and span of wood members used.

- **Hazards**

- Roofs covered with plywood or OSB will fail faster than those roofs covered with 1 x 6 sheathing.

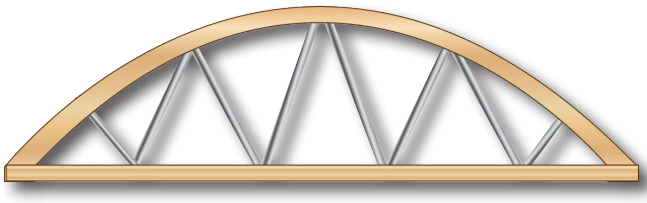

Figure 8-38 Bowstring Arch Truss

### *Bowstring Arch Truss*

Bowstring arched roofs have tie rods and turnbuckles that offer lateral support, Figure 8-38. Tie rods with turnbuckles are used below each arch member to support the exterior walls. Tie rods may pass through the exterior wall to an outside plate facilitating identification. Tension is maintained by turnbuckles. Top chords or arch members may utilize laminated 2 x 12's or larger. 2 x 10 inch rafters are covered by 1 x 6 inch sheathing and composition roofing material.

- **Strengths**

- Utilizes large sized lumber and 1 x 6 sheathing as the roof decking.
- Perimeter of the building and the arch members are the strongest areas of the roof.

- **Hazards**

- Failure of the metal tie rods and turnbuckles due to fire or heat.

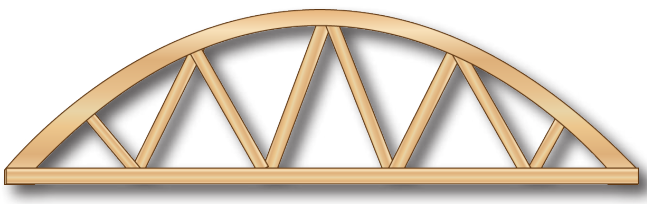

Figure 8-39 Ribbed Arch Truss

### *Ribbed Arch Truss*

Ribbed arched truss roofs are constructed with large size wooden members throughout. Some arches have multiple laminated beams to form one arch. Rafters are 2 x 10 or larger and covered with 1 x 6 sheathing and composition roofing material. The main difference between the ribbed arch and the bowstring is the absence of metal tie rods and turnbuckles, Figure 8-39. The ribbed arch truss utilizes solid wood members to construct its web. This trussed arch generally holds up well under fire conditions.





- **Strengths**
  - Utilizes large sized lumber for truss construction and 1 x 6 sheathing as the roof decking.
- **Hazards**
  - The use of metal fasteners and other components in this type of truss will typically be the cause for failure.

### Light Weight Roof Construction

Lightweight building and roof construction is currently very popular with architects and building contractors across the country. Considering the present cost of labor, equipment and building materials, it is not economically feasible to construct buildings the same as 50 years ago. Ease of installation and utilization of lightweight building materials have become the standard during the last 25 years. Heavy timber, laminated beams and 1 x 6 inch sheathing have been replaced by 2 x 4's and ½ inch plywood regardless of the building size. New style buildings with their characteristic concrete tilt-up walls, false fascias and flat roofs are other indications that lightweight construction may be present. As a result of architects' reducing the size of what there is to burn, today's fire departments are losing one of their most valuable fire ground factors, TIME.

Determining whether a roof is light weight or conventional style construction is a critical part to a firefighters size-up when fighting a structure fire.

#### *Panelized Roof Construction*

Panelized roofs are typically found on commercial structures constructed of wood, masonry or concrete tilt-up slabs. Although most commonly found in roof construction, panelized construction can also be found in floors. Panelized roofs do not have a space between the ceiling and the underside of the roof and consist of four main components, Figure 8-40.

- Beams
- Purlins
- Joists
- Decking

Panelized roof systems are constructed by laminating beams of various sizes; beams sizes of 6" x 36" is common for spanning across great distances. These beams are supported at either end by posts or pilasters with additional posts along the span as necessary. The beams can be spaced from 12 to 40 feet apart and may be bolted together to create lengths in excess of 100 feet.

Purlins are wooden members that are installed

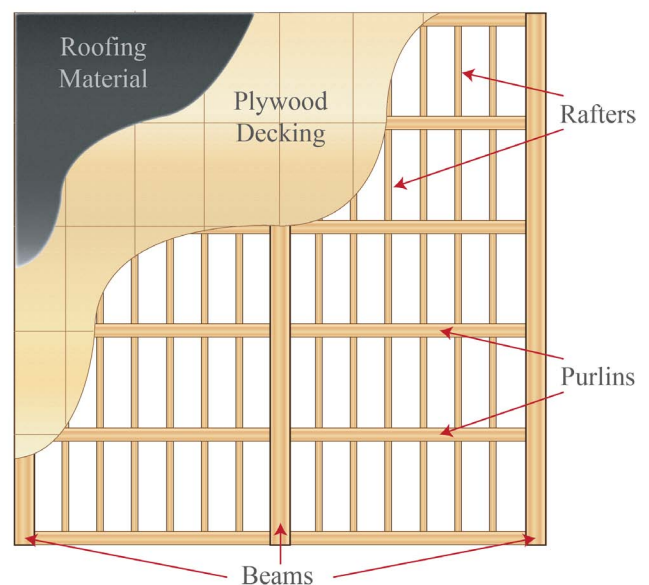

Figure 8-40 Panelized Roof System

from one beam to another beam with metal hangers every 8 feet. Purlins run perpendicular to the beams. The purlins are typically 4" x 12" in size with their length depending on the spacing between beams.

Joists typically are 2"x 4" x 8' in size and are installed every 2 feet connecting purlin to purlin. Joists run perpendicular to purlins and parallel to beams.

Sheets of plywood are nailed down over the panelized framework for decking and are covered with tar paper.

Although beams and purlins are constructed of heavy lumber, the joists, plywood decking and metal hangers in a panelized roofing system are quite weak. This is why panelized roofs are considered lightweight construction. A roof system is only as strong as its weakest link.

- **Strengths**

- The strengths of panelized roof systems are the beams, purlins and the perimeter of the building where the roof ties into the exterior walls.

- **Hazards**

- 2 x 4 joists, plywood decking, and metal hangers fail rapidly when exposed to fire.
- Panelized roofs are very heavy, when one support fails, expect collapse of a large portion of the roof.

#### *Lightweight Engineered Truss Construction*

A truss is a framed structure consisting of a triangle or multiple triangles joined together to carry a load across a span. Trusses can be built to hold a large amount of weight and maximize load bearing strength by taking advantage of the compression and tension properties created by the triangle shape. Trusses are not new construction techniques and have been used for centuries.

What is new about trusses is how engineers have designed them to use the least and cheapest amount of material to achieve their maximum load carrying capability. Trusses today are mass produced in an assembly line fashion off-site and shipped to construction sites pre-assembled. While this construction technique is very strong and appropriate under designed stress and static conditions, when fire and heat is introduced, they fail very rapidly and can become deadly to firefighters.

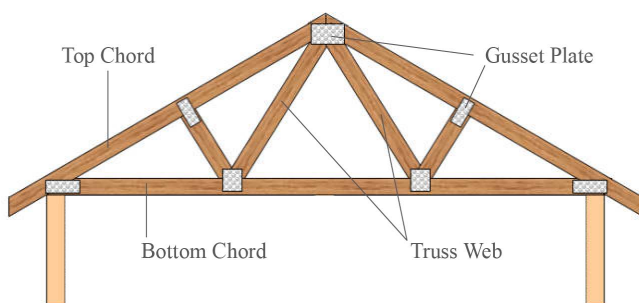

Figure 8-41 Components of a truss

Lightweight engineered trusses are used in both commercial and residential applications. They are constructed with wood 2 x 4's held together with metal gusset plate connectors or glue. Trusses are typically not supported by interior walls and are spaced 2 feet on center. These roof systems are then covered with plywood, tar paper and any number of roofing materials. Lightweight engineered truss construction can be found in floor systems as well as roofs, Figure 8-41.



Components of a truss:

- **Top Chord** – The top chord is the top horizontal member of the truss and is in the state of compression when loaded
- **Bottom Chord** – The bottom chord is the bottom horizontal member of the truss and is in the state of tension when loaded. In some truss designs, the bottom chord is not anchored to the exterior or load bearing wall.
- **Web** – The web is the diagonal cross braces that create a triangular pattern between the top and bottom chords. The web components of a truss can be either wood or metal.
- **Gusset Plates** – Gusset plates are thin steel plates with multiple steel prongs that penetrate into the wood, approximately 3/8", to fasten the wood truss joints. Spans of up to 55 feet can be found constructed of 2 x 4 wood trusses using gusset plates.

Strengths and hazards of a lightweight engineered truss:

- **Strengths**
  - The area where the truss crosses or ties into the exterior wall is the strongest area of the truss.
- **Hazards**
  - 2 x 4 inch wood with metal gusset plate connectors equals a short burning time before failure and collapse.
  - Trusses are under tension and compression relying on all members of the truss for its strength. When any one member of the truss fails, the whole truss will fail.
  - Metal gusset plates will pull out of the wood when exposed to fire and will cause truss failure.
  - The Top chord of the truss may be laid flat, only allowing for a 1 1/2" thickness of wood. When vertically ventilating, it is critical that the top chord is not cut causing the truss to fail.

#### *Wooden I Joist*

Wooden I joists have also become common place in many residential and commercial roof and flooring systems. Wooden I joists are similar in design to truss construction as they have similar components, Figure 8-42.

- Top Chord
- Bottom Chord
- 3/8" plywood or OSB stem

Instead of an open web consisting of wood or metal supports between the top and bottom chords, I joists utilize a solid piece of wood. The top and bottom chords are often as small as 2" x 3" wood and the plywood or OSB stem can be as thin as 3/8".



Figure 8-42 Wood I Joist



Media 8-1 Truss Failure caused by Fire

Wooden I joist construction does not use metal gusset plates, but rather relies on wood to connect the chords to the stem. These I joists have similar characteristics to the light weight truss and are considered extremely dangerous when exposed to heat or fire.

- **Strengths**
  - The perimeter of the building where the I joist ties into the exterior wall is the strongest area
- **Hazards**
  - It takes very little time for fire to burn through the chord and stem components due to their small size.
  - Like a truss, failure of any one component will cause the entire joist to fail.
  - It is common practice to cut holes in the stem of the I joist to run HVAC, electrical or plumbing, thereby weakening the joist.
  - Depth of cut during vertical ventilation is critical in order to avoid cutting the joist.

*Parallel Trusses*

Parallel Trusses are commonly found in newer commercial and concrete tilt-up construction. This type of roof construction provides an alternative to the panelized roofing method and can be found in businesses such as Costco and Home Depot. The use of a parallel truss as a roof component will always indicate lightweight roof construction and can be expected to perform poorly under fire conditions.

There are 3 types of parallel trusses that the firefighter will encounter, Figure 8-43

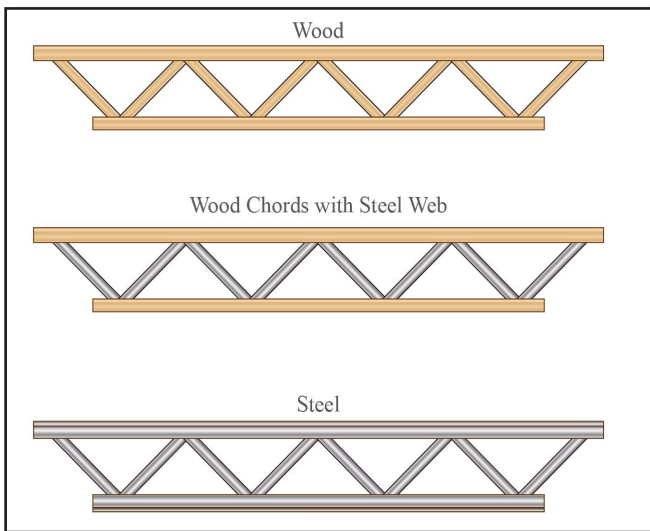

Figure 8-43 Parallel Trusses

- Wood
- Wood Chord with Steel Web
- Steel
- **Strengths**
  - The perimeter of the building where the truss ties into the exterior wall is the strongest area.
- **Hazards**
  - It takes very little time for fire to burn through the chord and web components due to their small size, Media 8-1.
  - Failure of any one component will cause the entire truss to fail.
  - The open web allows fire to travel and spread laterally.



## Basic Roof Styles



Gable



Hip

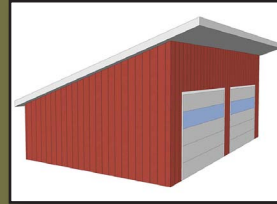

Shed



Butterfly



Gambrel



Mansard



Sawtooth



Arch & Dome

- Small dimension lumber is used for the chords, extreme care must be taken to not cut through them during vertical ventilation.

### Styles of Roofs

The following roof types summarize the majority of different types of roofs found in San Diego. There are several others, but in general they are a variation of these types. These roof types are characterized by their shape or style and may give you an indication of their construction. However, many different types of construction techniques are used to create these style roofs. Firefighters should not rely on the style of roof alone to indicate whether it is made using a lightweight or conventional construction.

- Gable Roof
- Hip Roof
- Shed Roof
- Flat Roof
- Butterfly Roof
- Gambrel Roof
- Mansard Roof
- Sawtooth Roof
- Dome or Arch (Bowstring)



## Ceilings

Ceilings cover the underside of rafters, joists, and trusses to create a separation of space (attic) between a room and the roof. There are two basic types of ceilings, conventional and suspended.

### Conventional Ceilings

Conventional ceilings are attached directly to the underside of the wooden rafters, joists, or trusses and are most commonly found in residential applications. Conventional ceilings are usually constructed from dry wall or wood paneling, but lath and plaster can also be found in older style ceiling construction.

### Suspended Ceilings

Suspended ceilings are most commonly known as “drop down” ceilings. These types of ceilings are found in commercial applications and consist of a system of suspended wires holding up lightweight panels. The void created by the drop down ceiling is referred to as the plenum, [Figure 8-44](#). Drop down ceilings are used to increase sound proofing and to hide utilities and HVAC systems which are commonly run overhead in commercial structures.

Drop down ceilings pose a real danger to firefighters. During a fire and extreme heat, the metal wires suspending the ceiling tiles will fail to maintain their integrity and drop down, hanging freely from the plenum space. These dangling wires create an entanglement problem and must be cut to free a firefighter. This is a very common hazard encountered during an interior attack in commercial structure fires.



Figure 8-44 The plenum, or space above a suspended ceiling

## Doors & Windows

Doors and windows provide very little structural integrity to a building. However, it is extremely important for firefighters to become familiar with the types and construction methods of doors and windows for rescue, forcible entry, and fire fighting operations.

Doors and windows are covered in depth in the Forcible Entry chapter of this drill manual.





# Building Construction Classifications

Buildings have been classified into five distinct types in order for firefighters to quickly recognize and understand the hazards associated with them. Structures are classified as Type I through Type V, with Type I being the most fire resistive and Type V being the least fire resistive. It is important to understand that these five categories are generalizations used to assist firefighters in making a quick size up. Firefighters must ensure that they do not make assumptions based upon the classifications alone, as many structures may be a hybrid of more than one category.

## Type I – Fire Resistive

Type I fire resistive construction is designed to confine fire and its by-products to a given location. Type I structures are built using structural steel and/or reinforced concrete, Figure 8-45. Their structural members are made of non-combustible or limited combustible materials. The code requires a rating of a minimum of 4 hours of fire resistance for all stairwells, bearing walls, elevator shafts, and columns. Floors and roofs shall be constructed of a non-combustible material such as concrete and drop down ceilings must be fire rated. Sprinklers, or a fire protection system, shall be present if the building is to be used for office or living space.



Figure 8-45 Type I Construction

There are several hazards associated with Type I construction. Fires can be difficult to fight due to the large size of the building and typical high fire load. Fire can spread from floor to floor in high-rises as windows break and through elevator shafts. If the fire resistive construction does fail, collapse can be catastrophic due to the size of these structures.

## Type II – Non-Combustible/Limited Combustible

Type II structures are constructed using a steel framework with exterior walls constructed of metal or concrete block, Figure 8-46. They are similar to Type I structures in that the structural members must be made from a non-combustible material, however, they have a lower degree of fire resistance for other components such as stairways, walls, doors etc. Another distinguishing characteristic is that steel members are not required to be coated with spray on fire-proofing insulation, making them prone to failure or collapse under fire conditions.



Figure 8-46 Type II Construction

Fires in type II structures are heavily influenced by the contents they contain. While the structure itself will not burn, the burning contents can cause quick failure of the steel components and their light weight roofs. It is also common for type II buildings

to have combustible facades or decorative construction attached to the fire resistive material.

## Type III – Ordinary Construction



Figure 8-47 Type III Construction

The Type III ordinary construction, also called “brick-and-joist,” has exterior walls of masonry with wood floors and wood roof, Figure 8-47. This construction method was used to build many of the public, commercial, and multiple unit dwellings throughout the country. These buildings are commonly found in the Gaslamp District of San Diego.

A structural hazard of an ordinary constructed building is the parapet wall, or the portion of the masonry wall that extends above the roof line. Type III construction also tends to be fairly old, therefore many of these buildings have undergone remodels and modifications leading to compromised walls and structural members. In older buildings, heavy timber beams are often only attached to walls by gravity. The ends of the beams sit inside a pocket of the wall or on a sill, known as a fire cut, Figure 8-48. If the floor or roof begins to sag, the end of the beams will shorten and dislodge, pulling out of the pockets or sills and cause the roof to collapse.

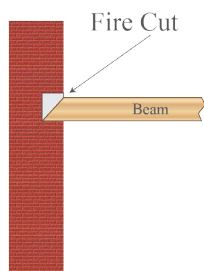

Figure 8-48 Fire Cut

Masonry walls gain their strength from compression. After a roof collapse, the free standing masonry wall has very little lateral support and is susceptible to fall over or collapse. More firefighter deaths have occurred in this type of structure than in any other.

## Type IV – Heavy Timber

Type IV structures are constructed of large dimensional wood, Figure 8-49. Exterior walls may be constructed of masonry or concrete block like a Type III. Type IV differs from type III in that interior walls and structural members such as beams, columns, arches, floors, and roofs are made from solid or laminated wood called heavy timber. These structures contain a heavy fire load due to the size of the structural timbers and are rarely used today other than churches and some factories.



Figure 8-49 Type IV Construction

Type IV structures allow for rapid fire spread due to their wide open nature in the interior. Because of the mass and exposure of large wood members, fire often burns for a long duration in these structures. Another serious hazard for firefighters is that of floor or roof collapse.



## Type V – Wood Frame Construction

Type V structures have interior and exterior structural members such as walls, floors, roofs, and other supports made completely or partially of small dimension wood and other combustible materials, Figure 8-50. Most residential dwellings are considered Type V construction.

The greatest hazard with this type of structure is the use of small wooden components to support larger components. When exposed to fire, there is unlimited potential for extension within the structure due to the abundance of concealed spaces. Structural failure or collapse is common. Rapid fire spread can be encountered in older Type V structures that utilize balloon construction due to the lack of fire stops between the studs in the walls.



Figure 8-50 Type V Construction

# Building Collapse



Figure 8-51 Signs of a weakened structure and potential building collapse

Firefighters must rely on building material knowledge, building construction principles, and an understanding of fire effects on buildings in order to predict or anticipate collapse. Waiting for a visual sign that a building will collapse is dangerous, especially in newer buildings. There are, however, some factors and observations that can be used to help anticipate collapse, Figure 8-51.

## Signs of Potential Collapse

- Smoke or water seeping through cracks in walls, floors or roof.
- Creaking or cracking noises.
- Excessive water in the building and/or lack of proper drainage.
- Bowing or bulging walls.
- Sagging or spongy roof, ceiling, or walls.
- Heavy fire impingement to any exposed structural members.
- Interior collapse or any partial collapse of the structure.
- Visible spalling.
- Deterioration of mortar joints and masonry.

## Buildings Under Construction

Buildings under construction pose an extra degree of danger to firefighters. During construction, many of the protective features and fire-resistive components have not been completed or installed. Buildings may only be in a partial state of completion. Structural members such as walls, roofs, beams, and trusses gain their strength and stability from each other. Any one missing component can create a very unstable structure. Additional items such as heavy stacks of wood or construction material may be found stored in these buildings under construction, often creating heavy concentrated loads.

## Time

All buildings will eventually fail or collapse if left to burn, Figure 8-52. Along with building construction, time is the other essential element that must be considered when combating a structure fire. There is no hard or fast set rule of how much time can pass before you must evacuate a structure. Each fire





and structure is unique, however, a few general guidelines can be followed to help the firefighter in determining when it is the right time to exit the structure.

- The lighter the structural element, the faster it comes down.
- The heavier the imposed load, the faster it comes down.
- Wetting and cooling steel structural members will buy you time.
- Brown or dark smoke coming from lightweight structural components means it is time to back out if it cannot be dampened.

An area surrounding the structure of at least 1 ½ times the building height should be kept clear of personnel, equipment, and apparatus whenever possible. This area is considered the collapse zone.



Figure 8-52 LA City Firefighters trapped after building collapse





# Summary

Many firefighters have been injured or killed as a result of building collapse during structural fire fighting. To prevent death and injury, it is important that firefighters understand the buildings in which they fight fires. This understanding comes from a long-term commitment to reading and studying building construction information. Additionally, firefighters must get into buildings within their districts to survey and explore the way buildings are assembled and used in the real world.

Knowledge of building construction starts with an understanding of loads, forces, and materials found in the structural makeup of buildings. Firefighters also study the effects of fires on materials and construction types. The five traditional types of construction are being challenged by new construction methods. Trusses are used in virtually all newly constructed buildings. Never trust a truss!

There are no rules for how long a building will last while on fire. Many factors determine when materials and construction design fail and result in a collapse. Understanding the process to proactively predict collapse helps firefighters communicate conditions and make observations that can save lives.



# Media & Links Index



Truss failure caused by fire



# References

1. (American Wood Council) [www.woodaware.info](http://www.woodaware.info), 1111 19th St. Suite 800, Washington, DC. 2006
2. Del Mar Cengage Learning, Firefighter's Handbook Chapter 13 Building Construction, 3rd Edition, Clifton Park, NY: Del Mar Cengage Learning, 2009.
3. Gaboury, James, Building Construction. SDFD Basic Fire Academy Lesson Plan and Power-Point, December 2003.
4. IFSTA, Essentials of Fire fighting, Chapter 4 Building Construction 5th Edition, Stillwater, OK.
5. SDFD Drill Manual, Chapter 9 Building Construction, 1994.
6. Smith, Michael. Building Construction. Methods and Materials for the Fire Service 2008 by Pearson Education, Inc. Upper Saddle River, NJ.
7. (The Constructor - Civil Engineering) - <http://theconstructor.org/structural-engg/analysis/types-of-loads-on-structure/1698/>
8. <http://publicecodes.citation.com/st/ca/st/index.htm>
9. <http://www.renovation-headquarters.com/platform-balloon-framing.html>
10. [http://www.firefighternation.com/forum/topics/what-do-you-know-about-parapet?xg\\_source=activity](http://www.firefighternation.com/forum/topics/what-do-you-know-about-parapet?xg_source=activity)

# Credits

## Writers:

John Brubaker, James Gaboury

## Layout & Editing:

John Brubaker

## Media:

John Brubaker, Steve Cowman

## Grammatical Editing:

Eric Matteson

***NOTE: If you have any additional information or content that you feel would be appropriate to contribute to this Chapter or would like to report any errors or misrepresentations, please contact the SDFD Training Division or email the Drill Manual Revision Staff at***

***SDFDDrillManualTeam@SanDiego.gov***

